

Mi-T-M[®] CORPORATION

8650 Enterprise Drive, Peosta IA 52068
563-556-7484 / Fax 563-556-1235
www.mitm.com

PARTS LIST FOR ***CW-2004-1ME1/1ME3*** (AFTER SERIAL #10002365)

Motor Horsepower:	5.0 HP
Pump Oil Grade:	Mi-T-M Pump Oil #AW-4085-0016
Pump Oil Capacity:	14 oz.
Nozzle Size:	5.0

This Parts Listing has been compiled for your benefit. You can be assured your Mi-T-M Cold Water Pressure Washer was constructed and designed with quality and performance in mind using over 25 years experience in the pressure washer business. Each component has been rigorously tested to insure the highest level of acceptance.

The contents of this Parts Listing are based on the latest product information available at the time of publication. Mi-T-M reserves the right to make changes in price, color, materials, equipment, specifications or models at any time without notice.

WARNING

THIS IS A PROFESSIONAL HIGH PRESSURE, COLD WATER PRESSURE WASHER. CAUTION SHOULD BE OBSERVED WHEN USING OR REPAIRING THIS UNIT! READ AND FOLLOW THE SAFETY WARNINGS LISTED BELOW BEFORE ATTEMPTING ANY REPAIRS ON THIS PRESSURE WASHER!

SAFETY WARNINGS

1. NEVER alter or modify the equipment. Be sure any accessory items and system components being used will withstand the pressure developed. Use only genuine Mi-T-M parts for repair of your pressure washer. Failure to do so can cause hazardous operating conditions and will VOID warranty.
2. NEVER make adjustments on machinery while the unit is connected to the power source. Turning over the machinery by hand during adjustment or cleaning might start the machinery, causing serious injury to the operator.
3. Know how to stop and bleed pressures quickly. Be thoroughly familiar with controls.
4. Before servicing the unit, turn unit off, relieve the water pressure and allow the unit to cool down. Do not make repairs while the unit is running. Service in a clean, dry, flat area.
5. After testing the machine, DO NOT leave the pressurized unit unattended. Shut off the unit and release trapped pressure before leaving.

Table of Contents

SPECIFICATIONS	3
FRAME ASSEMBLY FOR CW-2004-1ME1/1ME3 (AFTER SERIAL #10002365)	4
PUMP ASSEMBLY (3-0121)	6
UNLOADER ASSEMBLY (8-0316)	8
GUN ASSEMBLY (16-0001)	10
WIRING SCHEMATIC FOR CW-2004-1ME1 (230 VOLT)	12
WIRING DIAGRAM FOR CW-2004-1ME1 (230 VOLT)	12
WIRING SCHEMATIC FOR CW-2004-1ME3 (230 VOLT)	13
WIRING DIAGRAM FOR CW-2004-1ME3 (230 VOLT)	13
WIRING SCHEMATIC FOR CW-2004-1ME3 (480 VOLT) (CX-0002 OPTION)	14
WIRING DIAGRAM FOR CW-2004-1ME3 (480 VOLT) (CX-0002 OPTION)	14
NOTES	15

SPECIFICATIONS

CW-2004-1ME1/3

MODEL NUMBER	CW-2004-1ME1	CW-2004-1ME3
Operating Pressure (PSI/Bar):	2000/138	
High Pressure Nozzle:	5.0	
Water Volume (GPM/lpm):	3.6/13.6	
Motor:	Totally enclosed fan cooled, circuit breaker thermal overload protection, 35ft. power supply cord with Ground Fault Circuit Interrupter (GFCI)	
Horsepower	5.0	
Voltage	230	230/480
Phase	Single	Three
Amps	21.5	14/7
Pump:	Direct Driven, Oil Bath, Triplex Piston	
Oil Type	Mi-T-M Pump Oil #AW-4085-0016	
Oil Capacity (oz./liters)	14.0/.41	
Plungers	Ceramic Coated	
Manifold	Forged Brass	
Valves	Stainless Steel	
Unloader	Preset	
Heat Dump Valve	Relieves heated water during unloader bypass stage	
Unit Net Weight (lbs/Kg)	172/78	160/73
Unit Shipping Weight (lbs/Kg)	259/118	247/112
Unit Net Dimension (in/cm)	40x32.5x25.5/101.5x82.5x65	
Unit Shipping Dimension (in/cm)	48.5x30.5x35.5/123x77.5x90	

FRAME ASSEMBLY FOR CW-2004-1ME1/1ME3 (AFTER SERIAL #10002365)

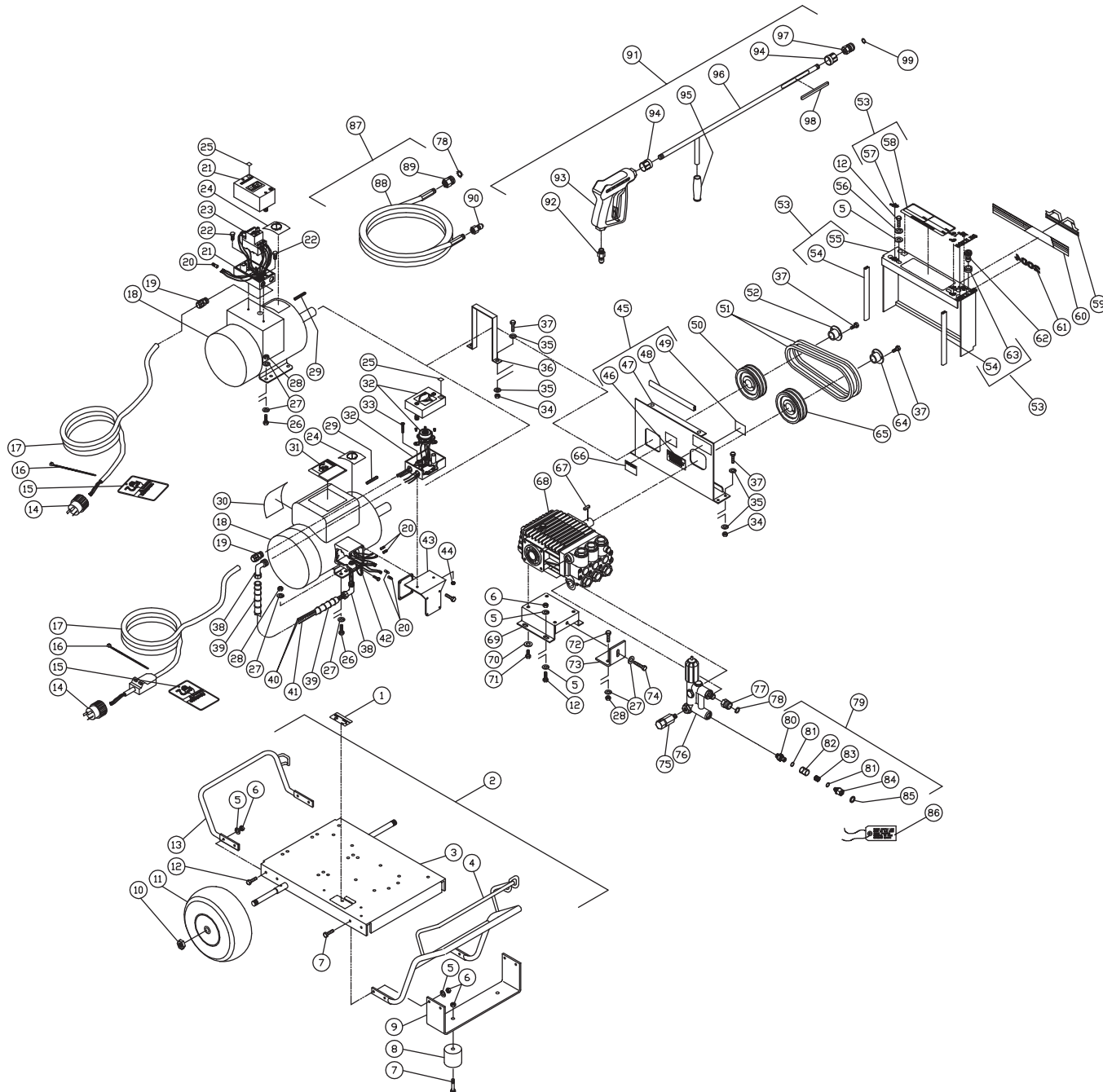

CW-2004-1ME1/3-092904-AJG

FRAME ASSEMBLY FOR CW-2004-1ME1/1ME3 (AFTER SERIAL #10002365)											
REF #	DESCRIPTION	PART #	QTY	REF #	DESCRIPTION	PART #	QTY	REF #	DESCRIPTION	PART #	QTY
1	Decal- Data Plate	N/A	1	32	Switch (CW-2004-1ME1)	32-0350	1	65	Sheave - Pump	10-0065	1
2	Base Plate Assembly (Inc. 3-13)	851-0211	1	33	Screw (CW-2004-1ME1)	27-2811	2	66	Decal - Important: Pump Instructions	34-0128	1
3	Base Plate	5-0090ULA01	1	34	Locknut	30-0155	6	67	Key - Pump	43-0028	1
4	Front Handle	7-0101A01	1	35	Washer	28-0002	12	68	Pump	3-0121	1
5	Washer	28-0003	18	36	Finger Guard	6-0054A01	1	69	Pump Bracket	5-0097A01	1
6	Locknut	30-0157	14	37	Bolt	27-0015	6	70	Washer	29-0054	4
7	Bolt	27-0068	6	38	Conduit Elbow (CW-2004-1ME1)	32-0254	2	71	Bolt	27-8042	4
8	Isolator	14-0008	2	39	Conduit (CW-2004-1ME1) *(One Foot Required)	32-0253	1	72	Bolt	27-0117	2
9	Underbracket	13-0042A01	1	40	Black Wire (CW-2004-1ME1) *(Four Feet Required)	32-0091	2	73	Brace Tightener	13-0005A01	1
10	Jamnut	30-0117	2	41	Green Wire (CW-2004-1ME1) *(Two Feet Required)	32-0248	1	74	Bolt	27-0576	1
11	Wheel	14-0006	2	42	Terminal (CW-2004-1ME1)	32-0034	1	75	Heat Dump Valve	22-0208	1
12	Bolt	27-0067	10	43	Mounting Bracket Switch (CW-2004-1ME1)	20-0317A01	1	76	Unloader	8-0316	1
13	Rear Handle	7-0104A01	1	44	Locknut (CW-2004-1ME1)	30-0154	2	77	Quick Connect Socket	17-0004	1
14	Plug- 230V (CW-2004-1ME1)	32-0029	1	45	Beltguard Back Assembly (Inc. 48-51)	851-0281	1	78	O-ring (Replacement Only)	25-0123	-
-	Plug- 230V (CW-2004-1ME3)	32-0118	1	46	Decal- Caution: High Pressure Spray	34-0080	1	79	Filter Assembly (Inc. 80-85)	19-0206	1
-	Plug- 480V (CW-2004-1ME3) (CX-0002)	32-0117	1	47	Beltguard Back (See 851-0281)	N/A Sep.	1	80	Inlet Filter (See 19-0206)	N/A Sep.	1
15	Tag - Risk of Electrocution	34-1035	1	48	Edging *(Two Feet Required)	33-0020	1	81	O-ring	25-0517	2
16	Cable Tie	33-0022	1	49	Decal- Warning: Do Not Remove	34-0575	1	82	Sight Glass	19-0208	1
17	Cord (CW-2004-1ME1) *(Thirty-five Feet Required)	32-0334	1	50	Sheave	10-0025	1	83	Strainer Screen	19-0209	1
-	Cord (CW-2004-1ME3) *(Ten Feet Required)	32-0025	1	51	Belt (CW-2004-1ME1)	11-0012	2	84	Inlet Filter (See 19-0206)	N/A Sep.	1
18	Motor - 5.0 HP (CW-2004-1ME1)	2-0078	1	-	Belt (CW-2004-1ME3)	11-0016	2	85	Garden Hose Gasket	26-0001	1
-	Motor - 5.0 HP (CW-2004-1ME3)	2-0091	1	52	Bushing (CW-2004-1ME1)	9-0008	1	86	Tag- Water Supply Inlet	34-0097	1
19	Cord Strain Relief (CW-2004-1ME1)	32-0358	1	-	Bushing (CW-2004-1ME3)	9-0010	1	87	Pressure Hose Assembly (Inc. 88-90)	851-0007	1
-	Cord Strain Relief (CW-2004-1ME3)	32-0013	1	53	Beltguard Cover Assembly (Inc. 54, 55, 57, 58, 63)	851-0282	1	88	Pressure Hose	15-0003	1
20	Crimped Wire Splice (CW-2004-1ME1)	32-0359	3	54	Edging *(Two Feet Required)	33-0020	1	89	Quick Connect Socket	17-0004	1
-	Crimped Wire Splice (CW-2004-1ME3)	32-0359	1	55	Beltguard Cover (See 851-0282)	N/A Sep.	1	90	Quick Connect Plug	17-0006	1
21	Starter Enclosure (CW-2004-1ME3)	32-0293	1	56	Lockwasher	29-0007	2	91	Gun/Wand Assembly (Inc. 92-97)	851-0200	1
22	Bolt (CW-2004-1ME3)	27-0017	1	57	Decal- Die Cut Nozzles	34-0500	1	92	Quick Connect Plug	17-0005	1
23	Starter- 230V (CW-2004-1ME3)	32-0297	1	58	Decal- Warning/Caution/Operation	34-0925	1	93	Gun	16-0001	1
-	Starter- 480V (CW-2004-1ME3) (CX-0002)	32-0296	1	59	Decal- Mi-T-M Logo	34-0086	1	94	Gun/Wand Connector	16-0182	2
24	Decal- Do Not Spray	34-0391	1	60	Decal- Mi-T-M Stripe	34-0003	1	95	Grip Handle	7-0002	1
25	Decal- Void if Removed	34-0085	1	61	Decal- Die Cut 2004	34-0036	1	96	Wand w/ 36" Handle	16-0206	1
26	Bolt	27-0118	4	62	Spray Nozzle- 0005	18-0003	1	97	Quick Connect Socket	17-0001	1
27	Washer	28-0023	11	-	Spray Nozzle- 1505	18-0004	1	98	Decal- Warning: Risk of Injection	34-0572	2
28	Locknut	30-0159	6	-	Spray Nozzle- 2505	18-0153	1	99	O-ring (Replacement)	25-0122	-
29	Key- Motor	43-0078	1	-	Spray Nozzle- 4005	18-0180	1	*Must Order in One Foot Lengths			
30	Decal- Operating Instructions (CW-2004-1ME1)	34-0432	1	63	Grommet	33-0001	5				
31	Decal- Warning: Risk of Electrocution (CW-2004-1ME1)	34-0431	1	64	Bushing	9-0017	1				

PUMP ASSEMBLY (3-0121)

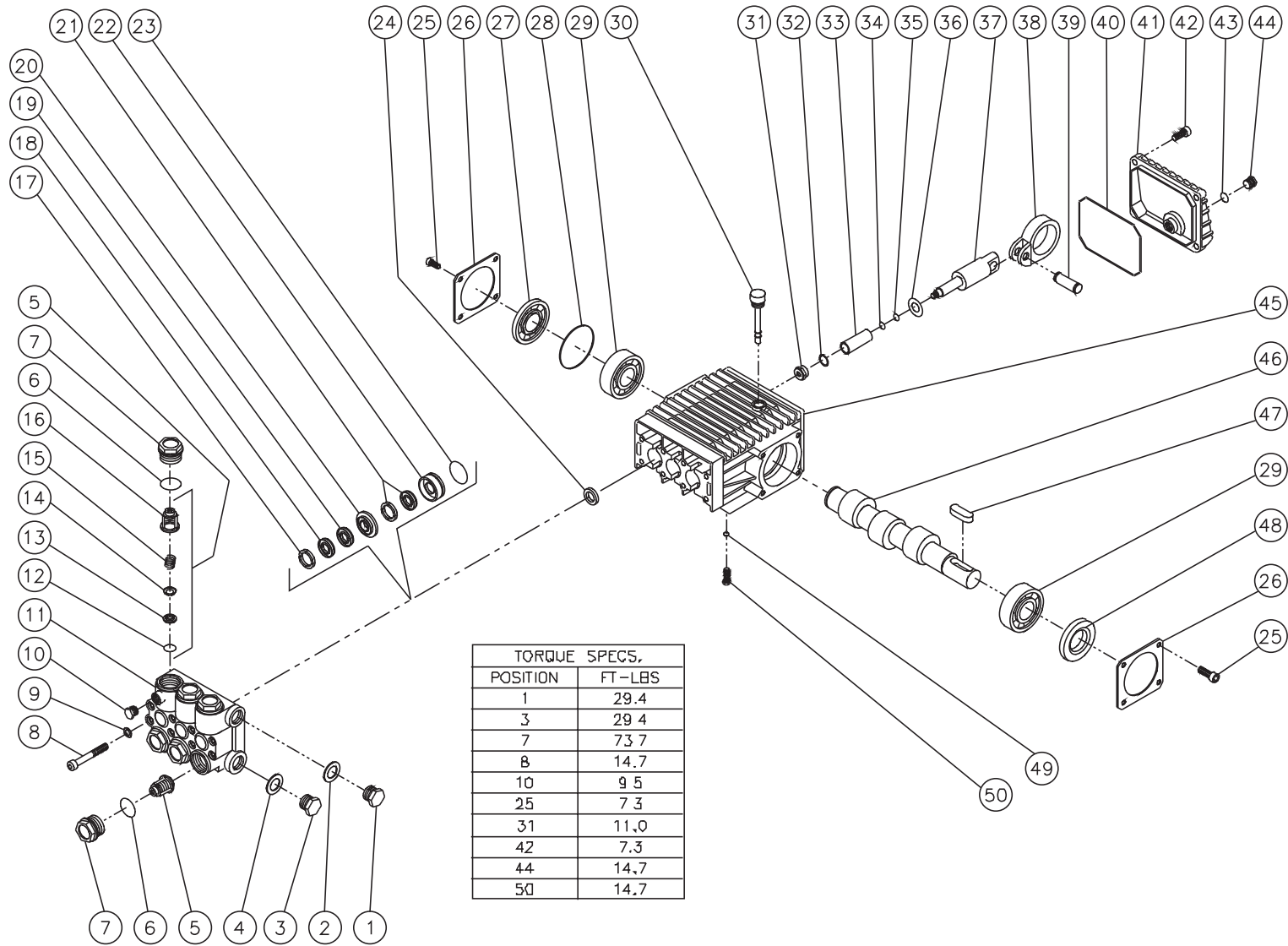

3-0121-042600-RD

PUMP ASSEMBLY (3-0121)											
REF. #	DESCRIPTION	PART #	QTY.	REF. #	DESCRIPTION	PART #	QTY.	REF. #	DESCRIPTION	PART #	QTY.
1	Bolt	39-0018	1	21	Low Pressure Seal (See 852-0114)	N/A Sep.	3	41	Crankcase Cover	46-0571	1
2	Washer	28-0600	1	22	Low Pressure Seal Retainer	46-0612	3	42	Bolt	27-8401	5
3	Plug	39-0019	1	23	O-ring	25-0048	3	43	O-ring	25-0014	1
4	Washer	28-0601	1	24	Oil Seal	26-0046	3	44	Plug	39-0017	1
5	Valve Assembly (Inc. 12-16) (See 70-0028)	N/A Sep.	6	25	Bolt	27-8000	4	45	Crankcase	46-0570	1
6	O-ring	25-0012	6	26	Retainer/Oil Level/Spacer	46-0084	1	46	Crankshaft	46-0601	1
7	Valve Plug	39-0071	6	27	Oil Level Indicator	46-0574	1	47	Key	46-0602	1
8	Bolt	27-8439	8	28	O-ring	25-0060	1	48	Oil Seal	46-0604	1
9	Lockwasher	29-0154	8	29	Ball Bearing	48-0050	1	49	Lockwasher	29-0054	4
10	Plug	39-0032	1	30	Oil Dip Stick	46-0143	1	50	Bolt	27-8042	4
11	Pump Manifold	46-0614	1	31	Nut	46-0168	3		Valve Kit (Inc. 6 each 5, 12-16)	70-0028	
12	O-ring (See 70-0028)	N/A Sep.	6	32	Washer	46-0166	3		Head Ring Kit (Inc. 3 each 17)	70-0026	
13	Valve Seat (See 70-0028)	N/A Sep.	6	33	Plunger	46-0603	3		Packing Kit (Inc. 3 each 18, 19, 21)	70-0025	
14	Valve Plate (See 70-0028)	N/A Sep.	6	34	O-ring	25-0045	3		Packing Assembly Kit (Inc. 3 each 17-19, 21)	852-0114	
15	Valve Spring (See 70-0028)	N/A Sep.	6	35	Back-up Ring	25-0143	3		Intermediate Retainer Kit (Inc. 3 each 20)	70-0122	
16	Valve Cage (See 70-0028)	N/A Sep.	6	36	Washer	28-1018	3		Retainer Kit (Inc. 3 each 22, 23)	70-0123	
17	High Pressure Head Ring (See 852-0114)	N/A Sep.	3	37	Piston Guide	46-0573	3		Packing Kit (Inc. 17-23)	70-0027	
18	High Pressure V-packing (See 852-0114)	N/A Sep.	3	38	Connecting Rod	46-0572	3		Pump- Short Block Kit (Inc. 24-48)	3-0135	
19	V-packing Support (See 852-0114)	N/A Sep.	3	39	Connecting Rod Pin	43-0079	3				
20	High Pressure Seal Retainer	46-0608	3	40	O-ring	25-0317	1				

UNLOADER ASSEMBLY (8-0316)

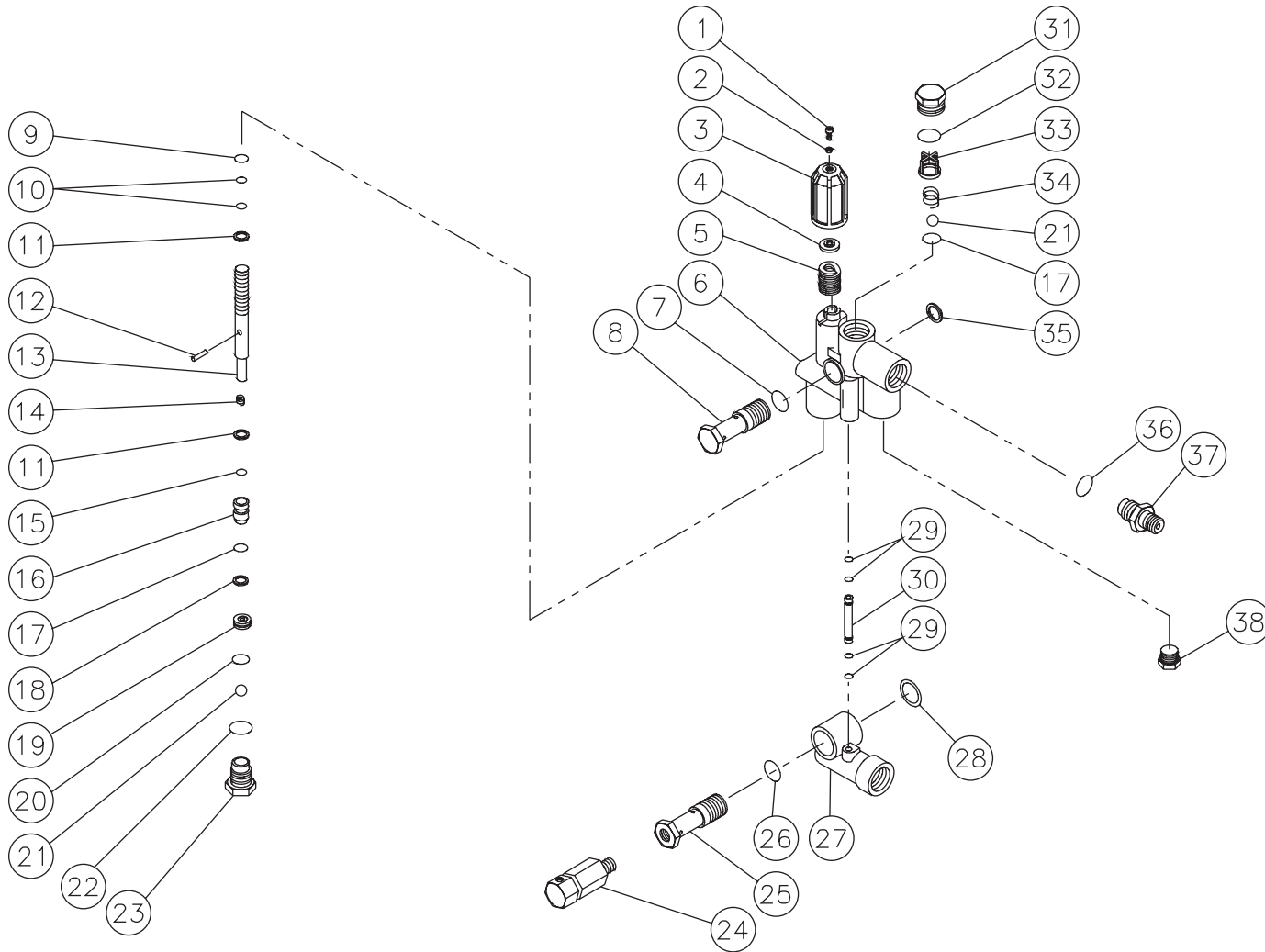

OMGEN195-022795-BAR

UNLOADER ASSEMBLY (8-0316)							
REF. #	DESCRIPTION	PART #	QTY.	REF. #	DESCRIPTION	PART #	QTY.
1	Screw	27-8409	1	21	Ball	8-0201	2
2	Nut	30-3024	1	22	O-ring	25-0160	1
3	Pressure Regulating Knob	7-0050	1	23	Cap	39-0039	1
4	Spring Guide	8-0332	1	24	Thermo Valve	22-0148	1
5	Spring	49-0047	1	25	Fixing Screw	8-0333	1
6	Valve Body	8-0218	1	26	O-ring	25-0053	1
7	O-ring	25-0231	1	27	Inlet Body	46-0242	1
8	Fixing Screw	8-0224	1	28	Washer	28-0601	1
9	Back-up Ring	25-0137	1	29	O-ring	25-0161	4
10	O-ring	25-0138	2	30	By-pass Tube	8-0223	1
11	Washer	28-0209	2	31	Cap	39-0040	1
12	Pin	43-0051	1	32	O-ring	25-0136	1
13	Piston Guide	8-0219	1	33	Valve Guide	8-0225	1
14	Spring	49-0049	1	34	Spring	49-0046	1
15	O-ring	25-0163	1	35	Washer	28-0600	1
16	Drive Piston	8-0220	1	36	O-ring	25-0051	1
17	O-ring	25-0050	2	37	Nipple	8-0130	1
18	Back-up Ring	8-0284	1	38	Cap	39-0042	1
19	Valve Seat	8-0221	1		Unloader Repair Kit (Inc. 5, 7, 9, 10, 14, 15, 17-22, 25, 28, 31-33)	70-0020	1
20	O-ring	25-0159	1				

WIRING SCHEMATIC FOR CW-2004-1ME1 (230 VOLT)

PD-CW-0107S-072595-DCE

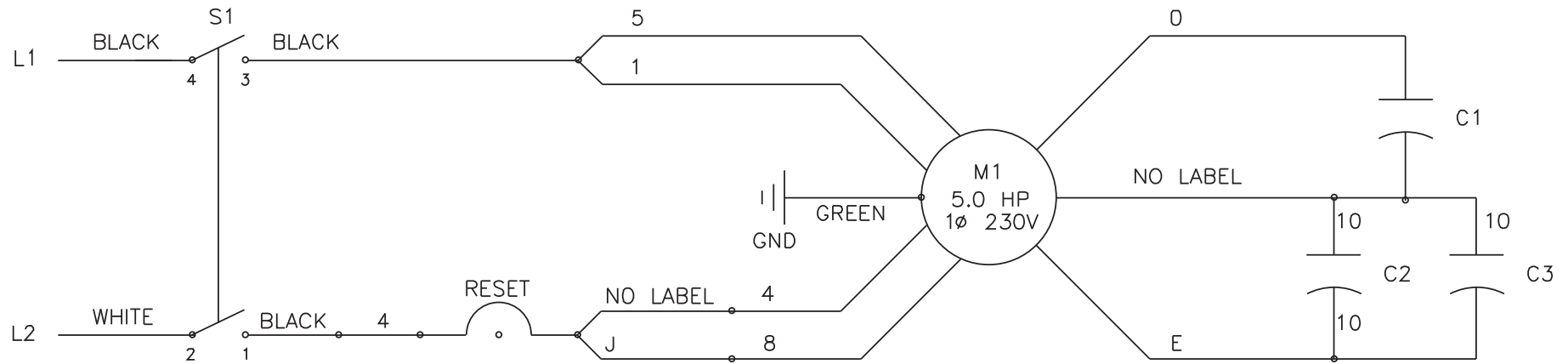

WIRING DIAGRAM FOR CW-2004-1ME1 (230 VOLT)

PD-CW-0107D-072595-DCE

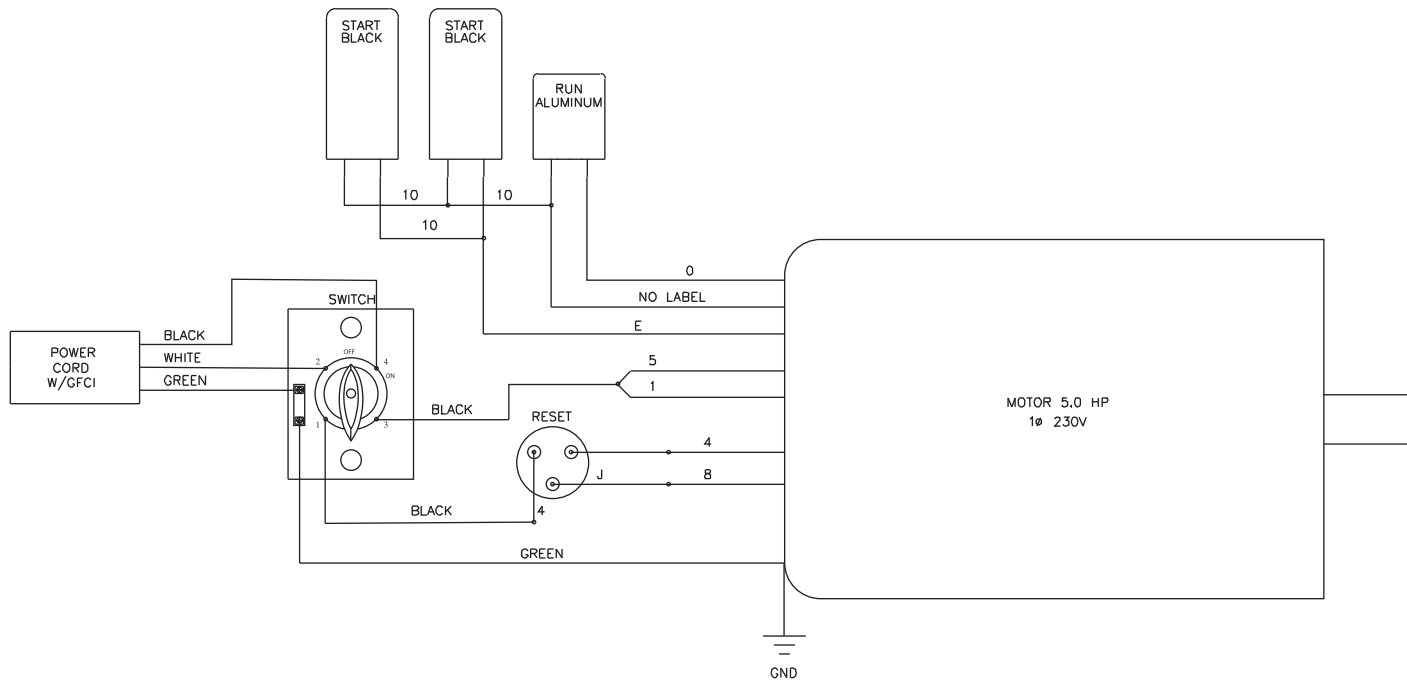

WIRING SCHEMATIC FOR CW-2004-1ME3 (230 VOLT)

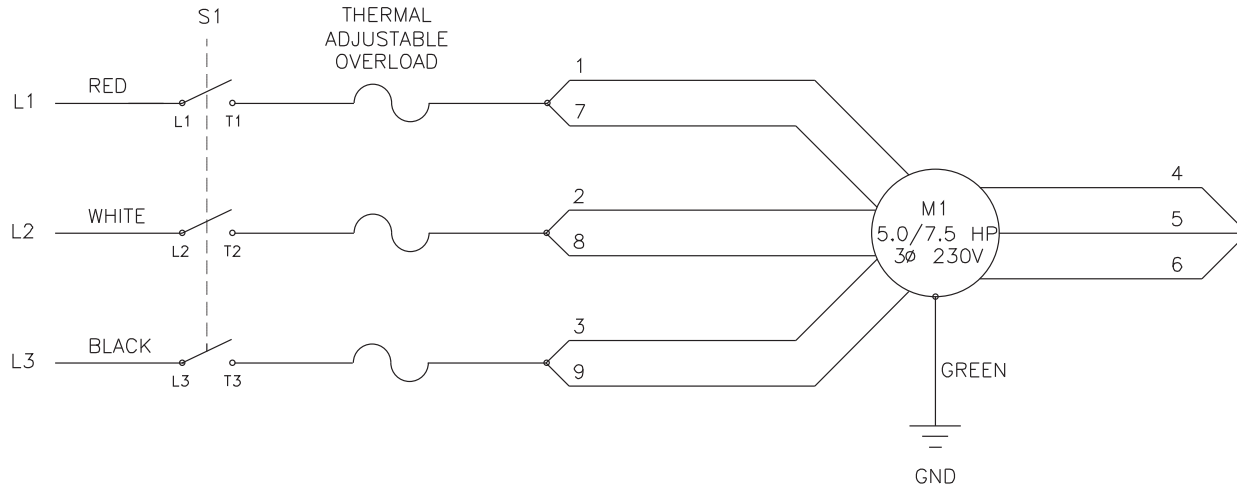

WIRING DIAGRAM FOR CW-2004-1ME3 (230 VOLT)

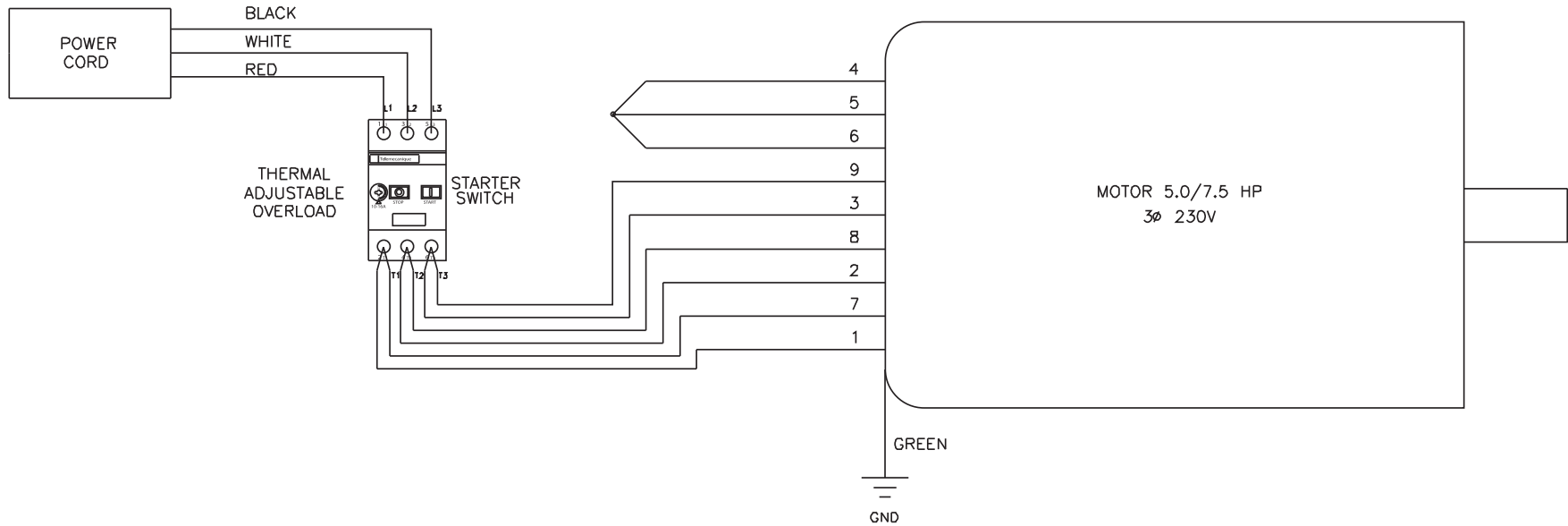

WIRING SCHEMATIC FOR CW-2004-1ME3 (480 VOLT) (CX-0002 OPTION)

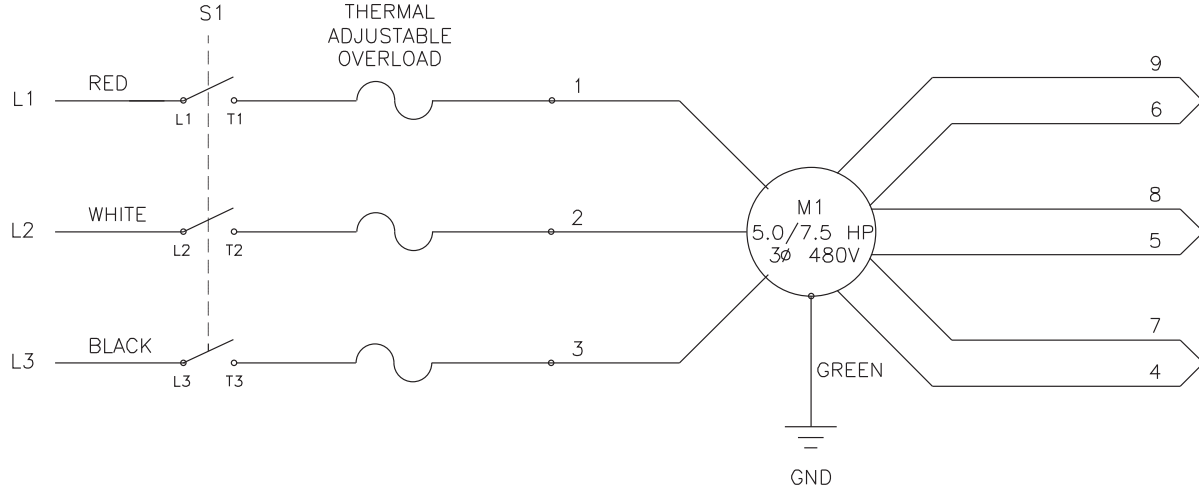

PD-CW-0109S-072595-DCE

WIRING DIAGRAM FOR CW-2004-1ME3 (480 VOLT) (CX-0002 OPTION)

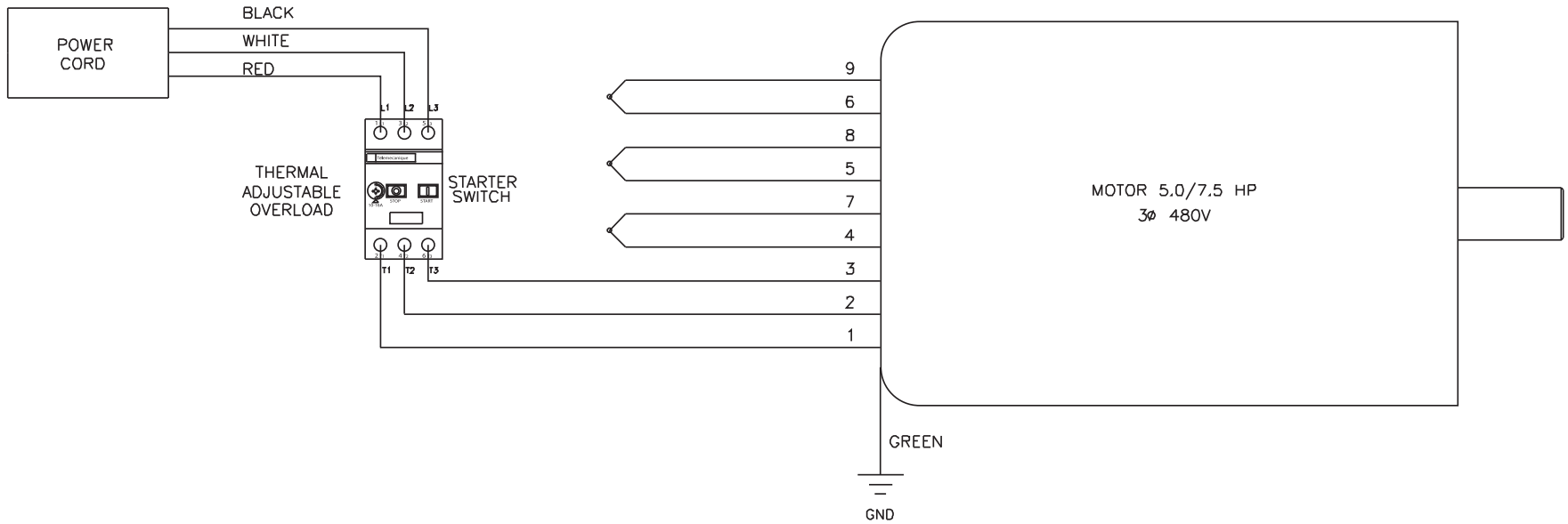

PD-CW-0109D-072595-DCE